



Sutton Decentralised  
Energy Network

# SDEN Residential Supply Agreement and Direct Debit Form





Sutton Decentralised Energy Network



Please fill in the whole form using a ball point pen and send it to:

Sutton Decentralised Energy Network
Civic Centre,
St. Nicholas Way,
Sutton, SM1 1EA

Name(s) of account holder(s)

Instruction to your bank or building society to pay by Direct Debit

Service user number

Table with 6 cells containing numbers: 1, 6, 8, 4, 1, 0

Reference

Bank/building society account number

Branch sort code

Name and full postal address of your bank or building society

To: The Manager

Bank/Building society

Date

Address

Postcode

Banks and building societies may not accept Direct Debit Instructions for some types of account.

This guarantee should be detached and retained by the payer.

The Direct Debit Guarantee

This Guarantee is offered by all banks and building societies that accept instructions to pay Direct Debits.

If there are any changes to the amount, date or frequency of your Direct Debit Sutton Decentralised Energy Network will notify you 10 working days in advance...

If an error is made in the payment of your Direct Debit, by Sutton Decentralised Energy Network or your bank or building society, you are entitled to a full and immediate refund...

You can cancel a Direct Debit at any time by simply contacting your bank or building society. Written confirmation may be required. Please also notify us.



# The Benefits of Direct Debit

The benefits are worth the few minutes it takes to set up a Direct Debit.

## It's guaranteed

Direct Debit payments come with a guarantee so you're automatically protected by three important safeguards:

- **An immediate money back guarantee from your bank in the event of an error in the payment of your Direct Debit.**
- **Advance notice if the date or amount changes.**
- **The right to cancel at any time.**

## It gives you peace of mind

Direct Debit is one of the safest and most reassuring ways of paying your bills:

- **Payments are made automatically, so bills are never forgotten, lost in the post or delayed by postal problems and there's no risk of late payment charges.**
- **Organisations using the Direct Debit scheme have to pass a careful vetting process, and are closely monitored by the banking industry.**
- **The Direct Debit Guarantee protects you and your money. It's offered by all banks and building societies that take part in the scheme.**

## It saves you time

Modern life is hectic – but Direct Debit helps. It takes away much of the hassle associated with paying bills, and puts an end to queuing at the bank and filling out cheques. You'll find it easier to stay on top of your bills, and you'll know exactly how much money is going out each month. For businesses paying by Direct Debit also means reduced workload and paperwork for your finance department.

## It spreads the costs

Paying your bills by Direct Debit can allow you to spread costs over a period that you agree with us.

# SDEN Residential Supply Agreement

Please complete this form in full. Failure to do so may result in delayed connection to the heat and hot water supply. We shall use the information provided to set up Your account. Data you provide may be shared with our Operations and Maintenance contractor and other third parties as may be required for the purpose of performing Our obligations under this Agreement. Please read the Customer Privacy Notice available to view on our website ([sden.org.uk/customers](https://sden.org.uk/customers)) prior to completing this form.

## Property details

Address

Postcode

Number of bedrooms

Property type

Date on which you will become the owner or tenant of the property

## Landlord details / Social Landlord Details (if applicable)

Title

Preferred Name

First Name

Surname

Correspondence address & postcode (if different to property address)

Home phone number

Mobile Number

Email address

## Customer 1 details

Title

Preferred Name

First name

Surname

Correspondence address & postcode (if different to property address)

Home phone number

Mobile number

Email address

## Customer 2 details

Title

Preferred Name

First name

Surname

Correspondence address & postcode (if different to property address)

Home phone number

Mobile number

Email address

## Security Questions

Please provide answers to two of the following security questions so we can identify You when You call Us:

Mother's Maiden Name

Name of first pet

A memorable place

Your favourite colour

### Marketing Preferences

Please tick to let Us know whether You would like to receive marketing communications from Us, such as information about our service, offers and discounts:

I consent to receive marketing communications from SDEN via email  via text message

**Payment notification** Please tick to let us know where to send your bill (if applicable)

Correspondence address

Property address

(Note: If you receive paperless billing by setting up your account online, you will be entitled to a discount of £5.90 per annum, upon request). If you choose to pay your bills by Direct Debit, you can have your bill emailed to you instead of being sent through the post. If you would rather we emailed you your bill, please let us know by ticking the box below.

Email: Email Address as above

(Note: If you pay by Direct Debit you will be entitled to a discount of £41.29 per annum, upon request)

\* If you no longer wish to receive marketing communications from Us, You can withdraw your consent at any time by contacting SDEN. For more information, please see the SDEN Customer Privacy Notice ([sden.org.uk/customers](https://sden.org.uk/customers))

This Agreement governs the supply by Sutton Decentralised Energy Network Limited (Company Number 10022446) (**We, Us, Our**) of space heating and hot water to the Customer (**You, Your**) at Your Home.

- A. We operate the district heating scheme which supplies space heating and hot water to Your Home.
- B. Your Home is part of the New Mill Quarter (the Development) which has been connected to the district heating scheme.
- C. You have requested that We make the Heat Supply available to You.
- D. This Agreement is a legal document. Words and phrases starting with capital letters have the meanings given to them in Clause 1.
- E. By signing this Agreement:
  - i. You are making a legally binding contract to comply with its terms;
  - ii. You agree to pay all Charges due to Us on time by variable direct debit (using the direct debit mandate attached) or by such other means as We may agree; and
  - iii. You confirm that You have read and understood the Agreement and the SDEN Customer Privacy Notice.

Please ensure that you read the terms of this Agreement carefully, and in particular the Clauses dealing with termination and disconnection of supply (Clause 7 (Termination and Suspension) and Clause 9 (Suspension and Reconnection)), those restricting Our liability to You in the event that We do not meet Our obligations under this Agreement (Clause 11 (Limitation of Liability)) and how We use Your personal information (Clause 13 (Use of Personal Information)). **For further information on when action may be taken on the disconnection or suspension of supply please also read our Policy Document**

(Reference: "SDEN Debt Recovery Policy (including suspension and disconnection of supplies)" which is available on request).

---

Please fill out the form on the front page of this Agreement, and sign in the space below to accept the terms of this Agreement. Where two customers are named above, please both sign below. Please then send this page and page 1 (together with Your Direct Debit form, if applicable) to Us along with a copy of proof of Your current address to the following address: **Sutton Decentralised Energy Network Limited Civic Centre, St. Nicholas Way, Sutton, England, SM1 1EA**

Alternatively, You can drop the completed form to Us in person at Our offices at the above address. However, please check Our website ([www.sden.org.uk](https://www.sden.org.uk)) for the latest COVID-19 updates.

You should keep a copy of the Agreement.

Signed  
(Customer 1)

Signed  
(Customer 2)

Name

Name

Date

Date

For office use

Date received

By email / post



# 1. Definitions

**“Data Protection Legislation”** (i) the GDPR, the LED and any applicable national implementing Laws as amended from time to time (ii) the DPA 2018 to the extent that it relates to processing of personal data and privacy; (iii) all applicable Law about the processing of personal data and privacy;

**“DPA 2018”** Data Protection Act 2018

**“GDPR”** the General Data Protection, Regulation (Regulation (EU) 2016/679)

**“LED”** Law Enforcement Directive (Directive (EU) 2016/680)

**“Abortive Call-out Charge”** means the charge for the second and subsequent Abortive Visits as set out in Schedule 1 (Our Charges).

**“Abortive Visit”** has the meaning set out in Clause 6.3.

**“Agreement”** means these terms and conditions and any schedules referred to.

**“BEAMA Labour and Material Indices”** means the indices for labour costs and materials costs provided by British Electrotechnical and Allied Manufacturers’ Association.

**“Bill”** means the statement or invoice We will send You periodically as contemplated in this Agreement.

**“Charges”** means:

- a. the Standing Charge and the Unit Charge;
- b. any Reconnection Charge;
- c. any Abortive Call-out Charge or Debt Processing Charge; and
- d. any other charges We are entitled to levy under this Agreement.

**“CPI”** means the Consumer Price Index issued by the Office of National Statistics.

**“Customer Meters”** means all of the meters (including the Meter) which measure the Heat Supply to each individual dwelling or commercial unit in the plot at the Development in which Your Home is located.

**“Debt Processing Charge”** means the charge to cover Our costs of processing and managing the collection of Your outstanding Charges as set

out in Schedule 1 (Our Charges).

**“Developer”** means the entity which has granted Us rights to operate the district heating scheme which supplies space heating and hot water to Your Home

**“Development Heating System”** means the heating and hot water system which has been installed by the Developer on the Development which We use to provide the Heat Supply up to the point of connection to Your Home’s Heating System. The Development Heating System is Our responsibility to operate, maintain and repair.

**“Estate Management Company”** means the company appointed (from time to time) to be responsible for the management of some or all of the common parts within the Development and their successors and assigns.

**“Extreme Cold”** means any period during which outside ambient temperature is under - 3°C.

**“Good Industry Practice”** means using the standards, practices, methods and procedures which comply with the Law and exercising that degree of skill, care, diligence, prudence and foresight which would reasonably and ordinarily be expected of a skilled and experienced person engaged in providing similar tasks under similar circumstances.

**“Heat Supply”** means hot water produced by the Development Heating System or the Sutton Decentralised Energy Network for the purposes of providing space heating and domestic hot water.

**“HIU”** means the heat interface unit that transfers heat from the Development Heating System to Your Home’s Heating System as shown on the HIU Drawing.

**“HIU Drawing”** means the schematic drawing set out in Schedule 3 (HIU Drawing).

**“ICIS Heren Offer Price for NBP Gas”** means the price indicator provided by ICIS Heren for natural gas.

**“Independent Meter Examiner”** means an independent third party which We may appoint from time to time to read the Meter.

**“Law”** means:

- e. any applicable statute or proclamation or any delegated or subordinate legislation;
- f. any enforceable community right within the meaning of section 2(1) European Communities Act 1972;
- g. any applicable guidance, direction or determination with which We and/ or the Developer is bound to comply to the extent that the same are published and publicly available or the existence or contents of them have been notified to them; and
- h. any applicable judgement of a relevant court of law which is binding in England.

**“Meter”** means the heat meter used to measure the amount of Heat Supply used by Your Home’s Heating System. We are responsible for the operation, repair and replacement of the Meter.

**“Our Website”** means the website accessible at the web address specified in the Welcome Pack and also stated in each Bill We send to You.

**“Prepayment Meter”** means any Meter installed by Us in accordance with the provisions of Clause 4.10 or otherwise.

**“Reconnection Charge”** means Our charge for recommencing the Heat Supply to Your Home as set out in Schedule 1 (Our Charges).

**“Reminder Letter”** means a letter notifying You that Charges are overdue for payment by You to Us and Reminder Letters shall mean more than one such letter.

**“Relevant Factors”** means the percentage increase in CPI, the increases in the BEAMA Labour and Material Indices and the relevant primary fuel price indicator in use at the time under Our agreement with the Developer (currently the ICIS Heren Offer Price for NPB Gas), together with various cost increases and decreases incurred by Us in providing the Heat Supply and running the System. Please read Our pricing policy for further information located on our website [www.sden.org.uk](http://www.sden.org.uk)

**“SDEN Customer Privacy Notice”** means SDEN’s privacy notice that explains how it processes customers’ personal information, made available online at: [www.sden.org.uk/customers](http://www.sden.org.uk/customers)

**“Service Failure”** means a failure by Us to meet a Service Standard.

**“Service Payments”** means any payments We are required to make to You in respect of a Service Failure.

**“Service Period”** means a continuous period of 12 months ending on 31 March. Where the Supply Start Date in the first calendar year during which You take the Heat Supply is after 31 March, the Service Period shall be the period from the Supply Start Date to the next 31 March.

**“Service Standards”** means the standards of service We agree to provide in respect of the Heat Supply under this Agreement. A copy of the Service Standards is set out in Schedule 2 (Service Standards and Service Failures), and they are also available on Our Website.

**“Standing Charge”** has the meaning given in Schedule 1 (Our Charges).

**“Summer Period”** means the period starting 1 May and ending 30 September.

**“System”** means the Development Heating System and the Sutton Decentralised Energy Network

**“Supply Start Date”** means the date specified in this Agreement or, where no date is specified, the date on which You first take the Heat Supply to Your Home.

**“Unit Charge”** has the meaning given in Schedule 1 (Our Charges).

**“Welcome Pack”** means the documents provided to You relating to the System, the Heat Supply and this Agreement. If You have not yet received the Welcome Pack please request one from Us.

**“Your Home”** means the property to be provided with the Heat Supply under this Agreement as specified under ‘Property Details’ in the table at the front of this Agreement, being the flat or house occupied or owned by You at the Development.

**“Your Home’s Heating System”** means the heating system inside Your Home including all pipes, radiators, hot water cylinders and other apparatus (but not including the Meter or the HIU) which is Your or Your landlord’s responsibility.

**“Winter Period”** means the period starting 1 October and ending 30 April.



## 1. Heat Supply

- 1.1 We shall provide the Heat Supply to Your Home and You shall pay for such Heat Supply on the terms of this Agreement. This Agreement is effective from the Supply Start Date until the Agreement is terminated in accordance with Clause 7 (Termination).
- 1.2 We will make the Heat Supply available to You at all times during the whole of the term of this Agreement, subject to:
  - a. any problem with or caused by Your Home's Heating System that prevents, interrupts, or otherwise restricts the Heat Supply.
  - b. any physical constraints of the System during any period of Extreme Cold during the Winter Period;
  - c. Our compliance with any requirement imposed by Law;
  - d. Our belief on reasonable grounds that it is necessary to do so, so as to avoid (i) endangering the life of any person or causing harm to any person; or (ii) material damage to property; or
  - e. any other express right of suspension contained in this Agreement.
- 1.3 You acknowledge that the Development has been developed on the basis that We will be the sole provider of hot water and space heating to each unit within the Development including Your Home.
- 1.4 You agree that You will not obtain a supply of hot water or space heating to Your Home other than from Us at any time during the term of this Agreement, except during a suspension or interruption of the Heat Supply to Your Home (other than where We have suspended the Heat Supply to Your Home pursuant to Clause 7.2 or Clause 9.1 of this Agreement).
- 1.5 As far as is reasonably practicable, and other than in respect of any maintenance of any Meter or HIU, We will only schedule planned maintenance which is likely to require Us to interrupt or otherwise adversely affect the Heat Supply to Your Home to occur during the Summer Period.

## 2. Standards of Service

- 2.1 We shall provide You with the Heat Supply to Your Home in accordance with Our Service Standards.
- 2.2 If You are dissatisfied with the service We provide to You, You should follow Our complaints procedure set out in Clause 12 (Dispute Resolution) and which is also included in the Welcome Pack and is available on Our Website.
- 2.3 We will pay You a Service Payment in respect of a Service Failure in accordance with Schedule 2 (Service Standards and Service Failures).

## 3. Metering

- 3.1 You will accept as accurate all Meter readings taken by Us unless there is an obvious error or the Meter is defective.
- 3.2 We will use reasonable endeavours to use actual Meter readings to calculate the Unit Charges, but will use reasonable estimates of consumption where this is not reasonably possible.
- 3.3 If You reasonably believe the Meter is defective or readings are inaccurate, You can ask Us to arrange a check to see if the Meter is reading correctly. You may also ask for a check by an Independent Meter Examiner. We may carry out a check or ask for an Independent Meter Examiner to check Your Meter at any time if We believe that Your Meter is not reading correctly.
- 3.4 If, following an inspection under Clause 3.3, the Meter is found to be defective or a Meter reading is shown to be inaccurate, We will adjust Your subsequent Bill to account for any inaccurate Meter readings. We may adjust an incorrect Meter reading based on our reasonable estimate of the amount of Heat Supply used by You.
- 3.5 If the Meter is found to be correct after You have asked Us to check its accuracy You will pay for any

reasonable costs We have incurred in checking the Meter under Clause

- 3.6 We will use reasonable endeavours to ensure that the Meter has an initial certified accuracy of +/-3%. If the Meter records errors in excess of this amount it shall be deemed to be inaccurate and We shall recalibrate, repair or replace the Meter promptly. We shall be responsible for the cost of such replacement or repair unless:
- a. the fault is due to Your act or omission; or
  - b. the fault is due to the act or omission of any third party for whom You are responsible, in which event You will pay the reasonable costs of the replacement or repair of the Meter.

## 4. Payment and Charges

- 4.1 You will be responsible for payment of the Charges in respect of the Heat Supply to Your Home until this Agreement is terminated in the way referred to Clause 7 (Termination) or including where:
- a. Your Home is vacant or is occupied by someone else;
  - b. the Heat Supply to Your Home is used by a third party at Your Home without Your knowledge or permission;
  - c. You do not use the Heat Supply to Your Home; and
  - d. the Heat Supply to Your Home is interrupted or unavailable for a period in circumstances expressly permitted elsewhere in this Agreement.
- 4.2 You shall pay Us for the Heat Supply provided to Your Home. You must pay Us the Charges plus VAT, as set out in Your Bill, within 14 days from the date of Your Bill.
- 4.3 You will pay the monthly Standing Charge and Unit Charge monthly in arrears. Both of these charges are listed in Schedule 1 (Our Charges).
- 4.4 The payments You must make to Us in respect of each Bill (or if You have
- a Prepayment Meter, the payments covered by the Prepayment Meter) will be:
- a. an amount in respect of the Charges;
  - b. any applicable VAT;
  - c. any amount We add to recover underpayments or overdue Charges properly incurred in accordance with guidance published by the Office of Gas and Electricity Markets (OFGEM)(or its relevant successors) in relation to backbilling for utility supplies (and as from time to time updated or replaced);
  - d. any reasonable and proper costs or charges arising from loss or damage We suffer that was caused by You and for which You are responsible under the terms of this Agreement; and
  - e. any other costs or charges made in accordance with the terms of this Agreement;
  - f. less any amounts We deduct for overpayments You have made or Service Payments.
- 4.5 The Bill We send You will set out:
- a. the period to which the Bill relates;
  - b. the amount of the Heat Supply to Your Home measured in kWh based on any readings of Your Meter (or Our reasonable estimate when such estimation is expressly permitted under the terms of this Agreement), including opening and closing Meter readings;
  - c. the price per kWh payable for the Heat Supply consumed;
  - d. the amount of the Standing Charge;
  - e. the payment plan You have selected, if relevant;
  - f. any Service Payments deducted following a Service Failure;
  - g. the amount of any credit that You have available, carried forward from Your previous Bill;
  - h. details of any payment made by You since the previous Bill;
  - i. an offer to provide all the information We are required to provide with Your Bill under this Agreement in large print;
  - j. a description of the possible

- methods of payment that are available to You, with relevant instructions;
  - k. the total payments to be debited from Your bank account and of any change to that amount;
  - l. the balance of Your account; and
  - m. Our contact details in the event that You wish to make a complaint or request further information, or for reporting emergencies or requesting energy efficiency advice, and the details of Our Website.
- 4.6 Where We have billed You based on an estimate of the Heat Supply consumed by Your Home and subsequently taken a Meter reading, We shall adjust Our next Bill to correct for the difference between the estimate and Your actual consumption based on the Meter reading and apply a credit or debit to Your account accordingly.
- 4.7 If at any point the total amount of payments You have made is less than the Charges incurred to date:
  - a. We may require that You pay the difference to Us within fourteen (14) days of the date of Our Bill; or
  - b. We may increase the amount debited from Your bank account so that We recover the difference over a period that is reasonably acceptable to Us.
- 4.8 We prefer You to pay by direct debit, and if You do pay Your Bill by direct debit, You will be entitled to a discount of £41.29 per annum, upon request, if claimed within 30 days of the start of each Service Period. Other methods of payment are available and are described on Our Website and will also be included with Your Bill. If You pay by any means other than by direct debit, or Your direct debit mandate is not honoured by Your bank for any reason,
- 4.9 If You choose to pay by direct debit You may elect to pay a set amount monthly in advance (a "Monthly Payment"). If You would like to pay in this way please notify Us and We will agree the initial level of Your Monthly Payments with You. Once You have started making Monthly Payments We will reconcile the amount You have paid with Your actual consumption based on the Meter reading every twelve (12) months and apply a credit or debit to Your account and/or vary the amount of Your Monthly Payment, as appropriate.
- 4.10 If We consider it necessary (including where You are unable to make payments by monthly direct debit or a reasonable alternative or You have not paid any of the Charges by the due date for payment) We may take any action We believe is appropriate, although We must act reasonably. This may involve:
  - a. agreeing with You a payment plan so You can pay the money You owe Us over a period of time at a rate that is affordable to You. Any payment plan may include a requirement that You keep Your account with Us in credit;
  - b. the installation of a Prepayment Meter to measure and control the Heat Supply to Your Home;
  - c. charging You interest on the unpaid amounts at 4% above the Bank of England base lending rate;
  - d. taking action to suspend the Heat Supply to Your Home; and
  - e. taking court action to recover outstanding Charges and other costs.
- 4.11 Where Your Heat Supply is received through a Prepayment Meter, the payments covered by the Prepayment Meter may be adjusted to take into account and allow Us to recover over such reasonable period as We shall decide the reasonable costs of providing and installing the Prepayment Meter.

## 4.12 Adjustment of Charges

4.12.1 We may adjust the Unit Charge and the Standing Charge once per year to take into account the change in the Relevant Factors. The Relevant Factors balance Your interests and those of other consumers, with Our commercial interests in providing Our services. Any other Charges will be increased once annually in accordance with Schedule 1 (Our Charges). On each occasion that We intend to adjust Our Charges We must tell You thirty (30) days in advance of any adjustment of Our Charges and confirm the basis on which such adjustment has been calculated. If You have any queries in relation to any increase in Our Charges You can contact Us and We will provide You with additional details on the basis on which such adjustment has been calculated.

4.12.2 We may also increase Our Charges where any taxes, levies or duties on the Heat Supply (other than corporation tax or any other similar tax on Our profits or gains) in effect at the Supply Start Date are increased or there is a change of Law relating to the production or provision of the Heat Supply which results in any new tax, levy, duty or impost (not in force at the Supply Start Date) being charged, levied or imposed on Us. If there is a reduction or discontinuance of taxes, levies or duties in effect as at the Supply Start Date We will reduce Our Charges according to the amount of relief to the extent that Our Charges apply such taxes, levies or duties. Any increase or decrease in Our Charges under this Clause 4.12.2 will apply from the date that the relevant change in relation to any tax, levy, duty or impost takes effect.

4.12.3 To the extent that any change, increase in cost or other circumstance would, but for this Clause 4.12.3, entitle Us to adjust the Charges pursuant to both Clause 4.12.1 and Clause 4.12.2 We shall only be entitled to adjust the Charges pursuant to one of those provisions in respect of the relevant change, increase in cost or other circumstance.

## 5. Meters, HIU and Equipment

### 5.1 Our Responsibility

5.1.1 We are responsible for:

- a. the inspection (which shall not be more frequently than once in every three years), maintenance, repair and/or replacement of the HIU and
- b. the maintenance, repair and/or replacement of the Meter, in accordance with Good Industry Practice. However, Our obligations are subject to the exclusions in Schedule 4 (HIU Exclusions).

5.1.2 If Your HIU requires maintenance, repair or replacement You can ask Us to arrange a visit to Your Home so that We can inspect the HIU and try to identify the problem and rectify it. We may also ask to be allowed to visit Your Home to inspect and (if necessary) carry out maintenance or repair or replacement of the HIU. We will give You at least three (3) days' notice of any such visit (or seven (7) days' notice in respect of planned routine maintenance) and will use reasonable endeavours to arrange for such check to take place at a mutually convenient time. Subject to Clause 5.1.5, if You report a problem with Your HIU to Us We will visit Your Home to address the problem within the following time periods from when You report the problem to Us:

- a. in emergencies, including where there is a substantial leak of any form from Your HIU – within four (4) hours;
- b. in any circumstance not within paragraph (a) above where You are experiencing a full or partial loss of the Heat Supply (b) within eight (8) hours, during a Winter Period or twenty four hours (24) in any Summer Period however for the purposes of determining whether We have complied with that eight (8) or twenty four (24) hour time period any period of time between the hours of 8.00pm

and 8.00am shall be disregarded; and

- c. in respect of any other problem
  - within forty eight (48) hours, however for the purposes of determining whether We have complied with that forty eight (48) hour time period any period of time between the hours of 8.00pm and 8.00am on Mondays to Fridays, and all day on a Saturday and Sunday shall be disregarded.

5.1.4 Subject to Clause 5.1.5, if You report a problem with Your Meter to Us We will visit Your Home to address the problem within 24 hours from when You report the problem to Us. However, for the purposes of determining whether We have complied with that twenty four (24) hour time period any period of time between the hours of 8.00pm and 8.00am shall be disregarded. When We visit Your Home We will endeavour to repair or correct the relevant problem or fault. If We require a part in order to do so which is not available to Us at the time We visit Your Home, We will agree a time with You for Us to visit Your Home again to repair or correct the problem or fault as soon as reasonably practicable after We are in possession of the required part.

5.1.5 We will, when You report a problem with Your Meter or HIU to Us, agree a four hour time period (within the relevant period of time permitted for Us to respond to the problem under Clause 5.1.3 or 5.1.4 (unless You ask Us to visit at another time ) ( the "Attendance Time") within which You must provide Us with such access to Your Home as We reasonably require to address the problem with Your HIU or Your Meter. We must visit Your Home within the Attendance Time in order to comply with Our obligations under Clause 5.1.3 and Clause 5.1.4 above. If We do so and You fail to provide Us with access to Your Home during the Attendance Time We will have been deemed to have complied with those obligations and, for the avoidance of doubt, Clause 6.3 will apply.

## 5.2 Your Responsibility and Liability

5.2.2 You or, if applicable, Your landlord must ensure that Your Home's Heating System is maintained and repaired and, where necessary, replaced and We shall not be liable for the cost of replacement or repairs of any part of Your Home's Heating System.

If the state of Your Home's Heating System is causing problems, or We believe on reasonable grounds that it is likely to cause problems, to the Development Heating System, Your Meter or Your HIU unless it is repaired or replaced, We may suspend the Heat Supply to Your Home until Your Home's Heating System has been repaired or replaced to Our reasonable satisfaction.

5.2.2 You are responsible for providing the electricity and mains cold water required by Your HIU.

5.2.3 You agree that You are responsible to Us for any damage or loss to the Development Heating System, Your Meter or Your HIU which in each case is caused by any work that You do or have done (other than where carried out by Us) to Your Home's Heating System (for example, where such loss or damage is caused by You draining Your Home's Heating System or moving radiators), or where You fail to maintain or repair Your Home's Heating System (for example by failing to repair leaks).

5.2.4 You or any third party must not (in respect of Your Meter and Your HIU to the extent that such Meter or HIU is within Your Home):

- a. tamper with or damage the Development Heating System, Your Meter or Your HIU; or
- b. misuse Your Home's Heating System so that it causes any damage to the Development Heating System, Your Meter or Your HIU

5.2.5 If any breach by You of Clause 5.2.4 causes damage to:

- a. the Development Heating System, You will be liable for the damage caused, including the costs of repair or replacement, We may

charge You for the reasonable costs that We incur in repairing the Development Heating System and replacing any relevant parts; or

b. Your Meter or Your HIU, and We are then unable to perform Our obligations under this Agreement in respect of Your Meter or Your HIU because of such damage, Our obligations in respect of Your Meter or Your HIU shall be suspended until such time as the damage has been repaired to the extent necessary to enable Us to perform such obligations in accordance with this Agreement.

5.2.6 You must inform Us immediately if You discover that any of the Development Heating System, Your Meter or Your HIU is damaged or destroyed, or if You become aware that anyone other than Us or Our agents interferes with or removes the Meter and/ or Your HIU or if You believe Your Meter or Your HIU has been damaged.

5.2.7 You agree that We shall not be responsible for failing to provide Our services under this Clause 5 (Meters, HIU and Equipment ) where We reasonably consider that there is a health and safety risk, including the presence of dangerous materials, infestations, or harassment to Our staff (including any verbal or physical abuse or threat of physical abuse).

## 6. Access

6.1 You will allow Us and Our duly authorised officers and agents safe and uninterrupted access to Your Home (without charge) to the extent that We reasonably require. Access will be at a mutually convenient time and We will give You reasonable notice (of not less than three (3) days' notice, or seven (7) days' notice in respect of planned routine maintenance) where such access is required, unless there is an emergency or unless We believe there is a danger to people or 2 property (which is likely to be material or to have a material economic

impact) or unless We are required by Law to obtain access sooner.

6.2. In addition to any other purpose expressly referred to in this Agreement, We may require access for the purposes of:

a. inspecting, operating, repairing, exchanging, installing, removing, testing, maintaining, or carrying out other activities in relation to Your Meter, Your HIU or the Development Heating System

b. suspending the Heat Supply to Your Home as permitted under the terms of this Agreement;

c. terminating this Agreement;

d. mitigating any danger We reasonably believe exists to people or property; and

e. any purpose required by Law.

6.3 If We agree a time with You for Us to visit Your Home for any purpose relating to this Agreement and You do not allow Us access at the agreed time then an "Abortive Visit" will be deemed to have occurred. Where We make more than one Abortive Visit to Your Home in respect of the same issue or for the same purpose You will be liable to pay Us the Abortive Call-out Charge in respect of each such Abortive Visit other than first such Abortive Visit.

6.4 If You do not allow Us reasonable access to Your Home when expressly required under this Agreement, and in circumstances where We have complied with Our obligations under this Agreement in respect of such access, We will refer the matter to the Estate Management Company who may, if they are entitled to do so, grant Us access to Your Home. If We are unable to gain access to Your Home through the Estate Management Company in such circumstances You will be liable for the reasonable additional costs incurred by Us in carrying out any work without access to Your Home (to the extent such work is necessary for the purpose for which access to Your Home has been sought).

## 7. Termination

- 7.1 We may terminate this Agreement without liability on written notice to You in accordance with Clause 7.2 if:
- You have not paid the Charges and We have complied with the provisions of Clause 9 (Suspension and Reconnection);
  - Our contractual obligation to make available the Heat Supply to Your Home under Our Agreement with the Developer ends or is terminated;
  - You no longer own or rent Your Home;
  - there is a fault with Your Home's Heating System which is materially adversely affecting the Development Heating System and such fault has remained unresolved for a continuous period of three (3) months or more since You became aware of the fault; or
  - there are circumstances beyond Our reasonable control (as specified in and governed by Clause 10 (Events Beyond Your Or Our Control) which mean We are not able to perform Our duties under this Agreement.
- 7.2 If We have the right to terminate this Agreement under Clause 7.1, We may instead choose to suspend this Agreement at Our discretion on seven (7) days' advance notice. If We suspend this Agreement in accordance with this Clause 7.2 We will reconnect the Heat Supply to Your Home and recommence performing Our obligations under this Agreement only if the circumstances of Clause 7.1 cease to apply and You have paid Us in full for any outstanding Charges due to Us and the Reconnection Charge. Before reconnecting the Heat Supply to Your Home We may also ask You to pay Us a deposit equivalent to Our reasonable estimate of Our likely Charges to You under this Agreement for a period of three (3) calendar months as set out in Clause 9.5(b) (and We will comply with Clause 9.6 if You pay Us a deposit under this Clause). However, We may still elect to terminate this Agreement if We choose to suspend this Agreement and the circumstances in

which We are required to reconnect the Heat Supply have not yet occurred.

- 7.3 In all cases, We shall provide You with at least seven (7) days' advance written notice of termination of this Agreement.
- 7.4 In the event that We terminate this Agreement under Clause 7.1 and, subsequently, the circumstances of Clause 7.1 cease to apply and You have paid Us in full for any outstanding Charges due to Us and the Reconnection Charge, We will enter into a new agreement with You on identical terms to this Agreement. Before reconnecting the Heat Supply to Your Home We may also ask You to pay Us a deposit equivalent to Our reasonable estimate of Our likely Charges to You under this Agreement for a period of three (3) calendar months as set out in Clause 9.5(b) (and We will comply with Clause 9.6 if You pay Us a deposit under this Clause). This Clause 7.4 shall survive termination of this Agreement in accordance with Clause 14.9.

### 7.5 Your Right to Terminate

- 7.5.1 You may terminate this Agreement at any point by providing Us with not less than 7 days' notice. You must notify Us that You wish to terminate this Agreement in writing, by emailing Us or using the Moving Out form provided on Our Website, which You can print, complete and send to Us by post or deliver to Our offices.
- 7.5.2 After You have given us such a notice You must provide Us a forwarding address so that We may contact You in respect of any Charges that You may owe Us, or any amounts that We may owe to You by completing the Moving Out form published on Our Website, or available from Us on request. We will take a final Meter reading on the date this Agreement terminates.

**PLEASE BE AWARE** that unless You give us notice that you no longer own or rent Your Home in accordance with this Clause 7 (Termination) You will continue to be liable for Our Charges, whether or not You occupy Your Home until You notify us that You have moved or another person takes responsibility for the Heat Supply to Your Home.

## 8. Consequences of Termination and Suspension

- 8.1 You must pay for the Heat Supply to Your Home up to and including the date of termination or suspension, and You will remain liable following termination or suspension for any other previous breach of this Agreement by You, and We will remain liable for the consequences of any previous breach by Us.
- 8.2 Where We exercise Our right to suspend the Heat Supply to Your Home or where this Agreement is terminated by either party, You must allow Us access to Your Home to suspend the Heat Supply to Your Home if necessary, and/or to alter or reconfigure the Meter or remove the Meter (with the consent of the owner of the Development), or any of Our equipment or anything else owned by Us and You must not reconnect the Heat Supply to Your Home without Our consent.
- 8.3 If You remain in occupation of Your Home and You take the Heat Supply to Your Home after termination or suspension, or allow anyone else to do so, You will be liable to pay Us for such Heat Supply to Your Home, at a price which We will notify You and in determining that price We shall have regard to any additional costs which We have incurred as a consequence of the Heat Supply to Your Home being taken.
- 8.4 Where Your Heat Supply is received through a Prepayment Meter and You terminate this Agreement, We will be entitled to retain the balance of any prepayment received after deduction of all Charges due under this Agreement to the extent necessary to cover any other payment to which We are entitled under this Agreement. Following deduction of such amounts, We will return any remaining balance.

## 9. Suspension and Reconnection

- 9.1 We may disconnect the Heat Supply to Your Home and suspend performance of Our obligations under this Agreement in respect of the Heat Supply:
  - a. If You have not paid the Charges and provided We have complied with the provisions of Clauses 9.2 and 9.3;
  - b. You are in material or persistent breach of the terms of this Agreement (other than Your obligation to pay the Charges);
  - c. You or any third party for whom You are responsible has attempted to use the Heat Supply to Your Home without Our consent or in a manner designed to enable You or that third party to take any Heat Supply from the System without paying Us for it; or
  - d. We believe on reasonable grounds that it is necessary to do so to avoid (i) endangering the life of any person; or (ii) endangering any physical property, provided that both the relevant damage to such property and its economic impact are likely to be material.
- 9.2 Where You have not paid the Charges, We shall issue You with:
  - a. a first Reminder Letter where payment of the Charges are at least one (1) day overdue;
  - b. a second Reminder Letter no less than seven (7) days after the first Reminder Letter where payment of the Charges are still overdue; and
  - c. a third Reminder Letter no less than seven (7) days after the second Reminder Letter where payment of the Charges are still overdue,
- 9.3 We shall not suspend the Heat Supply to Your Home unless We have issued each Reminder Letter in accordance with the timeframes set out in this Clause 9.2 and tried to contact You at least twice by phone after the second Reminder Letter but before the third Reminder Letter to notify You of the outstanding Charges. The third Reminder Letter will provide



You with ten (10) days advance notice of suspension. We will also notify the Estate Management Company that the Charges are overdue and that We may suspend the Heat Supply to Your Home.

- 9.4 You acknowledge that if You do not pay the Charges to Us within three days after We send You a third Reminder Letter We can charge You a Debt Processing Charge to cover Our costs of processing each Reminder Letter sent to You and managing the collection of Your outstanding Charges.
- 9.5 Where We have suspended this Agreement pursuant to Clause 9.1.1, provided that the relevant circumstances in Clause 9.1 cease to apply and You pay Us:
- in full all outstanding Charges due to Us, or We agree (at Our discretion) with You a plan under which You will pay back such outstanding Charges over an extended period of time, while also being provided with (and paying for) the Heat Supply;
  - where Clauses 9.1.1 and 9.1.3 apply, a deposit equivalent to Our reasonable estimate of Our likely Charges to You under this Agreement for a period of three (3) calendar months; and
  - the Reconnection Charge, We will, within two (2) business days of receipt of payment, reconnect the Heat Supply to Your Home and recommence performing Our obligations under this Agreement.
- 9.6 If You pay Us a deposit pursuant to Clause 9.5(b) We will promptly return that deposit to You if, at any time after any subsequent reconnection, You have over any continuous twelve (12) month period paid all amounts You are required to pay Us under this Agreement in full within the times permitted under this Agreement for such payments.
- 9.7 In all cases, we shall provide You with seven (7) days' advanced written notice of suspension of this Agreement.
- 9.8 Where the Heat Supply to Your Home has been suspended, We may terminate this Agreement pursuant to Clause 8.1 if:

- the Heat Supply to Your Home has been suspended for more than 40 days;
- We have sent You at least two (2) further Reminder Letters. Our final Reminder Letter will provide You with thirty (30) days' advance notice of termination of the Agreement; and
- We have attempted to visit You at Your Home (not less than ten (10) days prior to termination) to notify You of the outstanding Charges and give You notice of potential termination of this Agreement.

## 10. Events Beyond Your or Our Control

- 10.1 Neither You nor We will be liable for failure to comply with Our respective obligations under this Agreement where You or We are unable to comply with such obligations because of war, civil war, terrorism, civil conflict or nuclear, chemical or biological contamination or other reasonably analogous events or where You or We are prevented from performing Our obligations by events outside of Our reasonable control (except We will be liable where any such events are caused by Us or due to Our negligence) and provided that You or We have taken all reasonable steps to guard against and mitigate against such events. We undertake to inform You, and You undertake to inform Us in the event that We or You are encountering difficulties as a result such events within two days of the event arising. The obligations of both parties will be suspended until the event is resolved.

## 11. Limitation of Liability

- 11.1 We are not liable for any failure of or problems with Your Home's Heating System unless the relevant failure or problem is caused by any act or failure to act by us or breach of this Agreement by Us including, without limitation, Our obligations in respect

of the maintenance, repair and replacement of Your Meter and Your HIU as stipulated in this Agreement. Nothing in this Agreement:

- a. excludes Our liability for fraud or fraudulent misrepresentation;
- b. excludes Our liability for death or personal injury resulting from Our or Our employees, authorised officers and agents negligence; or
- c. affects Your statutory rights as a consumer.

11.3 Subject to Clause 11.2, if We or Our employees, authorised officers or agents do not comply with the terms of this Agreement We will not be liable to You for any loss or damage arising from any breach of this Agreement that could not have been reasonably expected when We entered this Agreement with You, nor will We be liable for any indirect loss, such as loss of profits, income, business or goodwill. We will be liable for direct loss or damage caused by Our negligence or breach of this Agreement provided that Our liability for such loss or damage in a twelve (12) month period shall be limited to £10,000 (ten thousand pounds), increased annually by the annual increase in CPI, for any one event, or any series of connected events.

11.4 Subject to Clause 11.2, if You do not comply with the terms of this Agreement You will not be liable to Us for any loss or damage arising from any breach of this Agreement that could not have been reasonably expected when You entered this Agreement with Us, nor will You be liable for any indirect loss, such as loss of profits, income, business or goodwill. You will be liable for direct loss or damage caused by Your negligence or breach of this Agreement provided that Your liability for such loss or damage in a twelve (12) month period shall be limited to £2,000, increased annually by the annual increase in CPI, for any one event, or any series of connected events.

11.5 The provisions of this Clause 11 do not affect Our obligations to operate the Heat Supply in accordance with the Service Standards nor Your rights to receive a

Service Payment pursuant to Schedule 2 (Service Standards and Service Failures).

11.6 If You do not comply with the terms of this Agreement You will not be liable to Us for any loss or damage arising from any breach by You of this Agreement that could not have been reasonably expected when We entered into this Agreement with You, nor will You be liable for any indirect loss, nor for any loss (whether direct or indirect) of profits, income, business or goodwill (provided that nothing in this Agreement shall limit Your liability to pay amounts (including interest on such amounts) due pursuant to this Agreement).

## 12. Dispute Resolution

12.1 **If You have a complaint about Our services, You should follow the procedure set out below:**

- a. In the first instance, please contact Our complaints management team who will attempt to resolve Your complaint. Their contact details are available on Our Website, or from Us on request.
- b. If You are not happy with the way in which Your complaint has been dealt with, please contact Our Managing Director. Their contact details are available on Our Website, or from Us on request.
- c. We will always try and resolve Your complaint as quickly as possible and We will notify the Estate Management Company of any complaint You make to Us.
- d. If Your complaint has not been resolved to Your satisfaction by any of the above measures within a reasonable time frame from the date on which You first contacted Us about that complaint (or such other period as directed by the Energy Ombudsman) then You may contact the Energy Ombudsman who can deal with Your complaint on Your behalf. Contact details for the Energy Ombudsman are available on Our Website, or from us on request. Any direction or determination

by the Energy Ombudsman in respect of Your complaint shall be final and binding on both You and Us.

12.2 The cost for making any complaint to the Energy Ombudsman shall be borne by Us, except that We may charge You for any costs charged to Us by the Energy Ombudsman where the Energy Ombudsman has dismissed any complaint brought by You on the grounds that it has no merit on two or more occasions in any twelve (12) month period.

## 13. Use of Personal Information

13.1 Information that You provide to Us, or that we hold about You or Your account or other people living at Your home will be used and stored in accordance with Data Protection Legislation, and in accordance with the SDEN Customer Privacy Notice.

13.2 As part of considering and agreeing a payment plan with You in accordance with Clause 4.10(a), We may carry out credit and fraud prevention checks with one or more licensed credit reference and fraud prevention agencies and the agencies may retain a record of the search. The records may be linked to records relating to other persons living at the same address and such may be taken into account in credit and fraud prevention checks. Information about the payment details of Your account may be recorded with one or more of credit reference and fraud prevention agencies and that information may be shared with other organisations to help make credit and insurance decisions about You and for debt collection and fraud prevention. If You provide false and inaccurate information and We suspect fraud, We may record this fact.

13.3 We may monitor or record any telephone calls You make to Us or We make to You to ensure Service Standards are being met and for the prevention and detection of fraud and unauthorised use.

## 14. General

14.1 If You let Your Home We will on request enter into a direct supply agreement with Your tenant. Where this occurs:

- a. We will provide a supply agreement in the same form as this Agreement to either You or Your tenant, as requested, for Your tenant to sign;
- b. this Agreement will be suspended from the date on which Our agreement with Your tenant commences. While this Agreement is suspended Our obligations and Your obligations under this Agreement shall not apply, including Your obligation to pay for any Charges incurred after the date of such suspension. This will not affect any liabilities incurred before the date of suspension;
- c. We will obtain a final pre-suspension Meter reading using Our automatic reading system. If We are unable to do so We may ask You to give us the final pre-suspension Meter reading;
- d. this Agreement will cease to be suspended on the date Our agreement with Your tenant terminates, however We must give You at least fourteen (14) days' notice in writing of the end of the suspension period before You become liable for any Charges under this Agreement;
- e. You must give Us notice if the letting with Your tenant comes to an end; and
- f. at the end of Our agreement with Your tenant We will obtain a final Meter reading using Our automatic reading system. If We are unable to do so We may ask Your tenant to give Us the final Meter reading or, if Your tenant does not provide such information, We may request the final Meter reading from You.

- 14.2 We will be entitled to assign or otherwise transfer Our rights and obligations under this Agreement at any time on written notice to You. We shall be able to subcontract any of Our obligations under this Agreement. You may not assign or otherwise transfer Your rights or obligations under this Agreement without Our prior written consent.
- 14.3 Any notices We are required or wish to give You under the Agreement will be accepted by You as properly given if delivered or sent to Your address for correspondence as stated in this Agreement or such other address as You may in future request Us to use. Any notices sent through the post shall be deemed to be delivered upon the earlier of actual receipt, or three (3) days from posting. Any notices delivered by hand shall be effective on delivery.
- 14.4 If We delay enforcement of or choose not to enforce Our rights under this agreement at any time this will not prevent Us from enforcing Our rights in future. For example, if We do not immediately take action to ask You for payment of Charges that You owe Us, this will not prevent Us from doing so in future.
- 14.5 If more than one person is named on Your account with Us, then each account holder is responsible for payment of the Charges, and We may claim any unpaid Charges due to Us from one or all of the account holders, provided that We may not recover more in total than We are owed under the terms of this Agreement.
- 14.6 This Agreement includes everything agreed between Us and You. Anything that happened or was written before about the subjects dealt with in this Agreement is superseded, including any provisions included in the Welcome Pack. Neither You nor We have relied on any representation or warranty that is not written in this Agreement.
- 14.7 No party can obtain any rights under this Agreement apart from You and Us. The Contracts (Rights of Third Parties) Act 1999 is excluded.
- 14.8 Each of the terms and conditions of this Agreement is separate. If We or You are told by a court or other authority that We or You cannot rely on a certain Clause, the other Clauses of this Agreement will still apply.
- 14.9 Termination of this Agreement shall not affect the continuance in force of any provision of this Agreement which is expressly or by implication intended to continue in force after termination, including Clause 4.2 and Clause 4.4 (each in respect of any Charges accrued prior to termination of this Agreement only), Clause 7.4, Clause 5.2, Clause 8.2, Clause 11 (LIMITATION OF LIABILITY, Clause 13 (USE OF PERSONAL INFORMATION), Cause 14.1 to Clause 14.9 (inclusive) and Clause 14.12.
- 14.10 If You contact Us, We can provide advice on how to reduce Your energy consumption and carbon emissions.
- 14.11 We may change the terms of this Agreement (except changes to the Charges which shall be governed solely by the provisions of Clause 4.12 and Schedule 1 (Our Charges), subject to Our agreement with the Developer and provided that We first obtain the written approval of the Developer. For example We may need to amend the terms to comply with the Law or any regulation of Our services, or because the terms on which we are permitted to provide a Heat Supply to Your Home have changed. We will make details of any changes to available on Our Website and will also give You at least 30 days' notice in writing of any change to the terms of this Agreement.
- 14.12 This Agreement will be governed by and construed in accordance with the laws of England, and both You and Us agree to submit to the exclusive jurisdiction of the English Courts.

# Schedule 1: Our Charges

## 1. Heat Supply Charges

Our charges to You will be made up of a Standing Charge payable monthly irrespective of the consumption of the Heat Supply to Your Home and a Unit Charge representing the consumption of the Heat Supply to Your Home:

These prices are correct as of 1 April 2023.

The Unit and Standing Charges quoted below are shown exclusive of 5% VAT (unless stated otherwise) and have been rounded to two decimal points, although will appear to four decimal points on Your statement.

### Unit Charge (with effect from 1 April 2023)

The Unit Charge for the 2023/24 Service Period is 6.87p per kWh (6.87p per kWh exclusive of VAT).

### Standing Charge (with effect from 1 April 2023)

**£1.075 per day for a 1 Bedroom Home, excluding VAT**

**£1.092 per day for a 2 Bedroom Home, excluding VAT**

**£1.108 per day for a 3 Bedroom Home, excluding VAT**

**£1.125 per day for a 4 Bedroom Home, excluding VAT**

## 2. Abortive Call-out Charge

The Abortive Call-out Charge is £134.75 We may increase the amount of the Abortive Call-out Charge annually on 31 March in accordance with the respective annual increase in CPI.

## 3. Debt Processing Charge

The Debt Processing Charge is £56.15 We may increase the amount of Debt Processing Charge annually on 31 March in accordance with the respective annual increase in CPI.

## 4. Reconnection Charge

The Reconnection Charge is £134.75 We may increase the amount of Reconnection Charge annually on 31 March in accordance with the respective annual increase in CPI.

## 5. Other Charges

Where We undertake any work in accordance with this Agreement that You are liable to pay Us for, We will charge You at the rates We have agreed with the Developer and as are set out on Our Website as amended from time to time.

# Schedule 2: Service Standards and Service Failures

- 1 Our Service Standards are set out below. We aim to meet Your expectations in respect of the Heat Supply to Your Home. We may update or improve the Service Standards without Your consent but not in any manner which would make the Service Standards less beneficial to You or less demanding on Us. Any change or update to the Service Standards will be initially published on Our Website and a paper copy sent to You as soon as possible.
- 2 In the event of a Service Failure, You will be entitled to have the relevant Service Payment credited against Your account. We will apply the total amount of the Service Payments accrued during the period to which any Bill relates (the "Total Service Payment") to that Bill in accordance with this Agreement. To the extent that the Total Service Payment is greater than the amount which would otherwise be payable under the relevant Bill in accordance with this Agreement, any excess shall be applied to the following Bill. If no further Bill is due to be raised, We will pay the relevant amount into Your bank account or send You a cheque.
- 3 Any Total Service Payment shall be calculated by Us, by adding up any Service Payments that have accrued to You as a result of Service Failures that have occurred over the period to which the relevant Bill relates. We may determine that a Total Service Payment be used to pay Your final Bill in the event that this Agreement is terminated.

Item	Standard	Required Service Level	Service Failure	Service Payment
GS1	Planned supply interruption	Prior notice to You by Us of scheduled maintenance works to the System that interrupt the supply of heat to Your Home	Less than five (5) working days' notice of supply interruption	<b>£22.46</b> per instance <b>Capped at £336.88</b> per Service Period If claimed by You within 3 months
GS2	Unplanned supply interruption	The Heat Supply (with water within the temperature range required under Our agreement with the Developer) will be available to the point of connection to Your Home's Heating System within 24 hours of the start of any unplanned interruption	On failure to achieve this, a fixed compensation payment will be paid by Us to You, and a further payment will be made for each additional period of 24 hours until Your supply is restored	<b>£33.69</b> per instance <b>Capped at £336.88</b> per Service Period
GS3	Meter repair or replacement	Meter accuracy to be maintained within the requirements We have agreed with the Developer and an initial accuracy of +/-3%	Faulty Meter not replaced twenty eight (28) days after a fault is shown to exist	<b>£28.07</b> per instance <b>Capped at £224.59</b> per Service Period

Item	Standard	Required Service Level	Service Failure	Service Payment
GS4	Notifying customers that a penalty payment is due & making payments owed	We shall write to You within ten (10) working days of the date we become aware of any overpayment by You or of any compensation falling due to You and shall make the relevant payment to You within a further ten (10) working days	Where We fail to achieve this level of service, a fixed compensation payment will be made	<b>£22.46</b> per instance <b>Capped at £224.59</b> per Service Period
GS5	Responding Substantially to a Complaint	Substantially respond to a complaint within ten (10) working days or twenty (20) working days where a site visit or third party enquiries are required. However, if a substantive response is unable to be provided because a site visit is required, we will provide an initial response indicating this within ten (10) working days	Where we fail to achieve this level of service, a fixed payment will be made in respect of the initial failure and each succeeding five (5) working days during which the failure continues.	<b>£22.46</b> <b>Capped at £112.29</b> per Service Period







The Service Payments and each related cap shall be increased annually on 31 March in accordance with the respective annual increase in CPI.

Notwithstanding the above, no Service Payment will be payable to You if the relevant Service Failure is caused by one of the circumstances set out below.

GS2 and GS3	The Service Failure was caused by a breach of this Agreement by You
GS2 only	<p>We are prevented from making the Heat Supply to Your Home by any of the circumstances set out in Clause 10 (Events Beyond Our Control ), provided that We have used reasonable endeavours to mitigate the consequences of any such circumstances and resume provision of the Heat Supply as soon as possible.</p> <p>We are required by Law to shut down the System or the Development Heating System provided that the need to shut down the System does not relate to or arise out of any breach of this Agreement by Us or any negligent act or omission by Us.</p> <p>We have suspended the Heat Supply because We believe on reasonable grounds that it is necessary to do so to avoid:</p> <ul style="list-style-type: none"> <li>i. endangering the life of any person; or</li> <li>ii. endangering any physical property, provided that both the relevant damage to such property and its economic impact are likely to be material, provided, in each case, that the need to suspend the Heat Supply does not relate to or arise out of any breach of this Agreement or any negligent act or omission by Us.</li> </ul> <p>We have suspended the Heat Supply to Your Home pursuant to Clause 7.1 or Clause 9.1 of this Agreement</p> <p>Any event which causes an interruption to Your Heat Supply and to the heat supply of more than 2,000 of Our customers at the same time</p>

# Schedule 3: HUI Drawing

## KEY

-  Isolator Valve
-  Strainer
-  2 Port Control Valve
-  Differential Pressure Control Valve
-  Pump
-  Thermal Link
-  Hot Meter

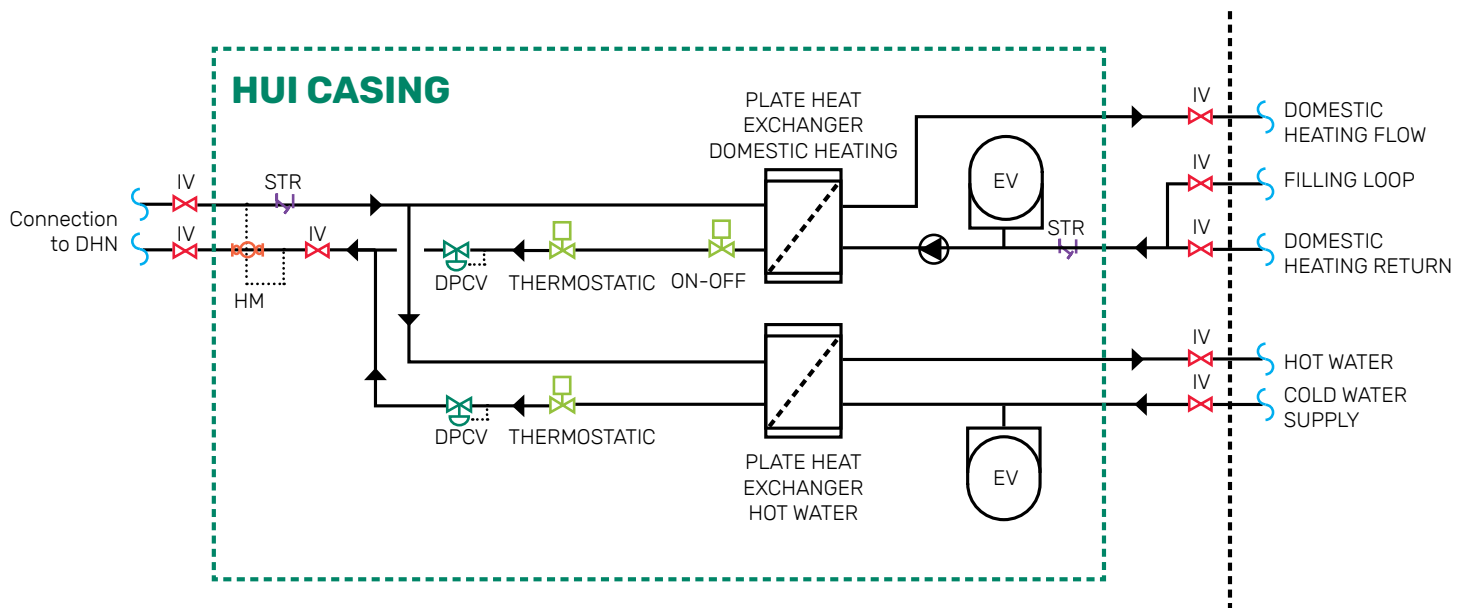



# Schedule 4: HIU Exclusions

In relation to Our obligation to maintain, repair or replace Your HIU We will not be liable for the following:

- 1 The costs of repair to the HIU where such repair is required due to damage to the HIU caused by You, or where work is undertaken on the HIU by someone other than Us or Our employees agents or contractors;
- 2 Any loss or damage to property as a result of the HIU or Your Home's Heating System breaking or failing, including any cleaning needed, or any damage to Your belonging, fixtures or furniture, unless such loss or damage is caused by Us or Our employees agents or contractors;
- 3 Making good any holes or surfaces beyond filling them in or making surfaces level;
- 4 Repairing faults or damage caused by subsidence, structural repairs, accident, fire, lightning, explosion, flood (unless in each such case caused or contributed to by Us or Our employees agents or contractors) or storm or freezing weather conditions;
- 5 Any costs to gain access to the HIU (such as removing Your fixtures and fittings or repairing and making them good) other than removing an access panel or opening cupboard doors or obtaining access through access points designed by the Developer of Your Home;
- 6 Replacement of any appliances, bathroom fixtures, showers and sanitary ware unless such loss or damage is caused or contributed to by Us or Our employees agents or contractors;
- 7 Upgrades that You may want to have carried out to improve the HIU or Your Home's Heating System;
- 8 Replacing or repairing parts which do not affect how the HIU or Your Home's Heating System works or performs (for example any decorative parts);
- 9 Resetting the HIU controls, such as thermostats or programmers following changes due to Winter or Summer Periods;
- 10 Providing cash alternatives instead of Us performing any of Our maintenance, repair or replacement obligations;
- 11 The costs of repairing damage or breakdowns caused by changes to or problems with any other utility services (except the provision of the Heat Supply);
- 12 Loss or damage to the HIU or Your Home's Heating System if radio frequency allocations are subsequently altered and they interfere with the HIU or Your Home's Heating System or any controls;
- 13 Replacing any batteries in any controls that operate the HIU or Your Home's Heating System;
- 14 Removing sludge or hardwater scale from Your Home's Heating System or any appliance, or repairing damage caused to the HIU or Your Home's Heating System by sludge or hardwater scale within Your Home's Heating System unless caused by Us or Our employees agents or contractors; or
- 15 The water treatment of any water circuits in Your Home's Heating System except where Your Home's Heating System is drained by Us to enable us to comply with Our obligations under this Agreement

